



ALCHEMY CASTINGS
563 KENILWORTH AVE N
HAMILTON, ONTARIO
CANADA - L8H 4T8

TOLL FREE: (866) 312-9084
Telephone: (905) 312-9084
Fax: (905) 312-9085

www.alchemycastings.com

COMMERCIAL ANODES



Alchemy Zinc Anodes are made to meet or exceed military specifications, including MIL-A-18001, the accepted authority used by governments of both Canada and the USA.



Cathodic Protection of Commercial Vessels, Piers, Dry docks, Retaining Walls, Off-Shore Drilling Platforms, Pleasurecraft & Oceanographic Equipment.

HULL ANODES (Medium to Large Vessels)

APPLICATIONS: Hulls, Sea Tanks, Bilges, Bottom Plates, Keels, Rudders, Shaft Tunnels, Ballast Tanks, Cargo Tanks, Structures.

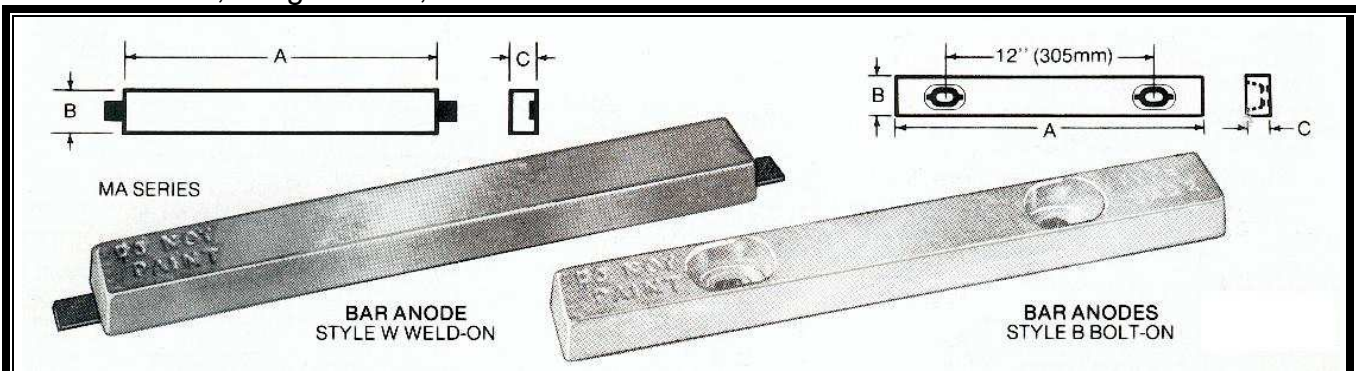

PART No.	Weight (Lbs)	A	B	C	MOUNTING
BAR ANODES					
P5B2	23.5	24.0"	3.0"	1.25"	Bolt-On
P7B2	47	24.0"	4.0"	2.0"	Bolt-On
ZHS-50	50	24.0"	4.0"	2.0"	Weld-On
ZMA 2204	47.5	20.0"	4.0"	2.0"	Weld-On
ZMA 2244	57	24.0"	4.0"	2.0"	Weld-On
ZMA 3305	71.5	30.0"	5.0"	3.0"	Weld-On
ZMA 3365	88	36.0"	5.0"	3.0"	Weld-On
ZMA 4545	207	54.5"	4.5"	3.75"	Weld-On



ALCHEMY CASTINGS
563 KENILWORTH AVE N
HAMILTON, ONTARIO
CANADA - L8H 4T8

TOLL FREE: (866) 312-9084
Telephone: (905) 312-9084
Fax: (905) 312-9085

www.alchemycastings.com

COMMERCIAL ANODES

HULL ANODES (Medium to Large Vessels) - Continued

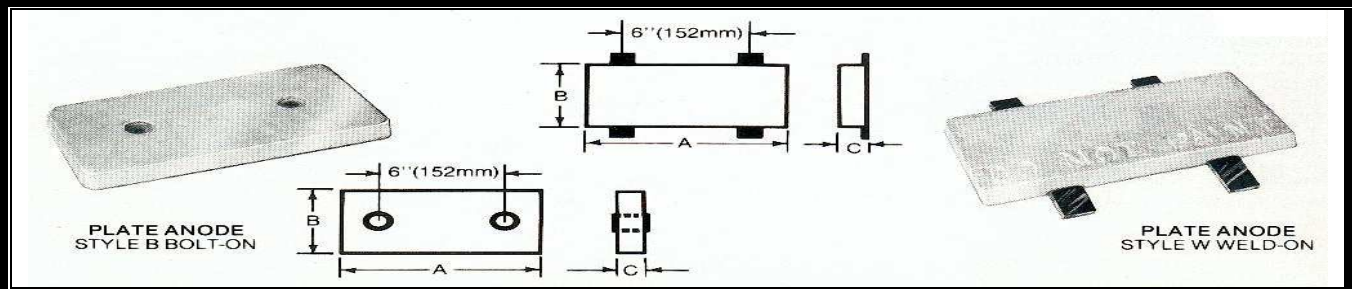

PART No.	Weight (Lbs)	A	B	C	MOUNTING
BAR ANODES					
ZHC-2	2.5	5.75"	2.75"	0.75"	Bolt-On
ZHC-23	23	12.0"	6.0"	1.25"	Bolt-On
ZHS-23	23.5	12.0"	6.0"	1.25"	Weld-On
ZHC-47	47	12.0"	6.0"	2.5"	Bolt-On
ZHS-47	47	12.0"	6.0"	2.5"	Weld-On

SEMI-STREAMLINED ANODES (Small to Large Vessels)

APPLICATIONS: Hulls, Sea Tanks, Bilges, Ballast Tanks, Structures.

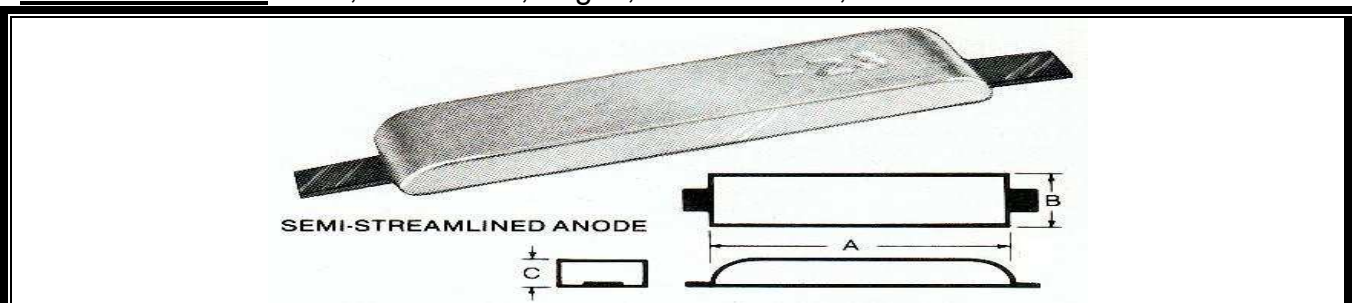

PART No.	Weight (Lbs)	A	B	C	MOUNTING
Z3	11.8	12.0"	3.0"	1.25"	Weld-On
Z4	5	6.0"	3.5"	1.0"	Weld-On
Z6	3	5.0"	2.5"	1.0"	Weld-On
Z19	23.5	25.0"	3.125"	1.25"	Weld-On



ALCHEMY CASTINGS
 563 KENILWORTH AVE N
 HAMILTON, ONTARIO
 CANADA - L8H 4T8

TOLL FREE: (866) 312-9084
 Telephone: (905) 312-9084
 Fax: (905) 312-9085

www.alchemycastings.com

COMMERCIAL ANODES

STREAMLINED ANODES (Large Vessels)

APPLICATIONS: Bilges, Ballast Tanks, Bottom Plates, Keels, Rudders, Shaft Tunnels, Cargo Tanks, Structures.

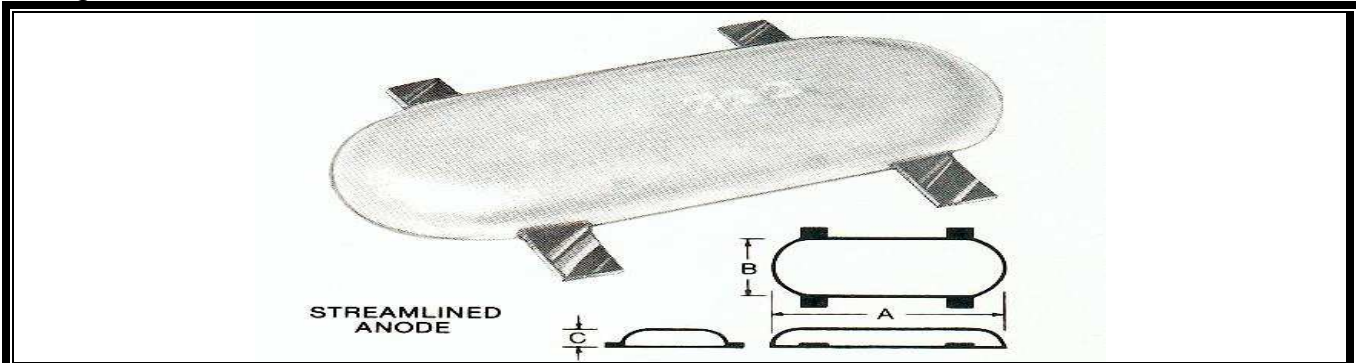

PART No.	Weight (Lbs)	A	B	C	MOUNTING
Z22	23.5	14.0"	6.5"	1.5"	Weld-On

TEARDROP ANODES (Small to Medium Vessels, Equipment)

APPLICATIONS: Rudders, Hulls, Equipment, Structures.

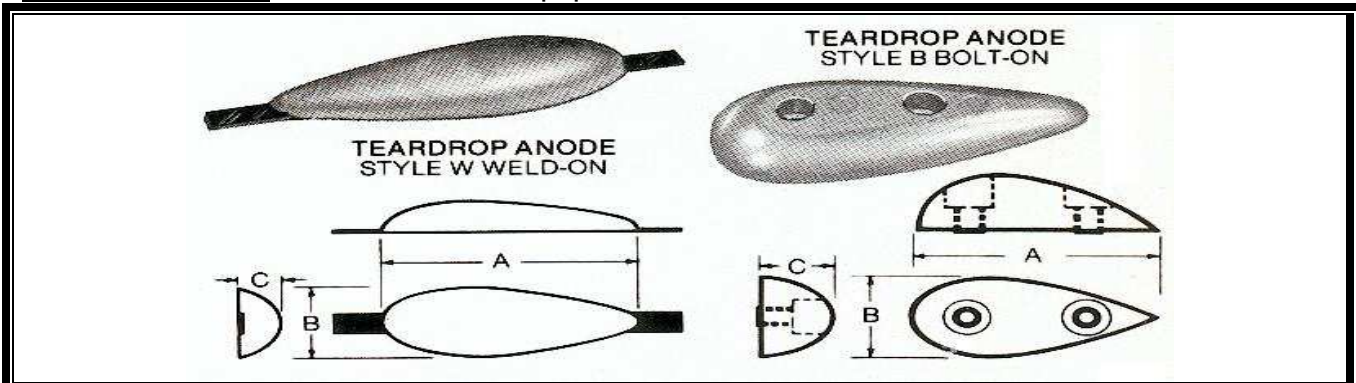

PART No.	Weight (Lbs)	A	B	C	MOUNTING
Z12	0.75	4.0"	1.25"	0.75"	Bolt-On
Z13	1.5	6.0"	1.75"	1.0"	Bolt-On
Z14	3.25	8.0"	2.625"	1.5"	Bolt-On
ZTS	5	9.0"	3.0"	1.375"	Weld-On



ALCHEMY CASTINGS
563 KENILWORTH AVE N
HAMILTON, ONTARIO
CANADA - L8H 4T8

TOLL FREE: (866) 312-9084
Telephone: (905) 312-9084
Fax: (905) 312-9085

www.alchemycastings.com

COMMERCIAL ANODES

HEATER EXCHANGER ANODES (Small to Large Vessels)

APPLICATIONS: Heat Exchangers, Evaporators, Condensers, Sea Chests, Water Circulating Systems, Process Equipment, Small Hulls, Structures.

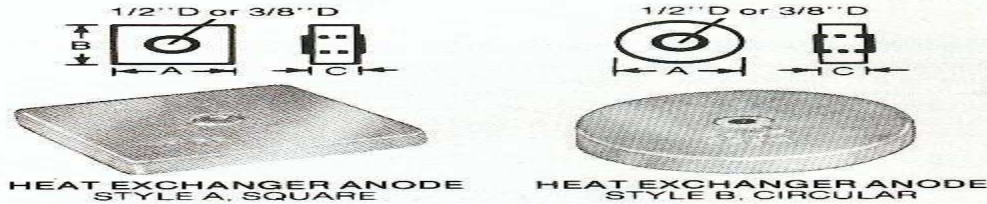

PART No.	Weight (Lbs)	A	B	C	MOUNTING
STYLE A, SQUARE					
H1B6	9.0	6.0"	6.0"	1.0"	Bolt-On
STYLE B, CIRCULAR					
H2B2	0.8	2.0" Dia	-	1.0"	Bolt-On
H2B3	1.8	3.0" Dia	-	1.0"	Bolt-On
H2B4	3.2	4.0" Dia	-	1.0"	Bolt-On
H2B5	4.9	5.0" Dia	-	1.0"	Bolt-On
H2B6	7.1	6.0" Dia	-	1.0"	Bolt-On
H2B9	16	9.0" Dia	-	1.0"	Bolt-On
H2B11	24	11.0" Dia	-	1.0"	Bolt-On

SPECIFY HOLE SIZE: 1/2" OR 3/8".

HEATER TREATER ANODES

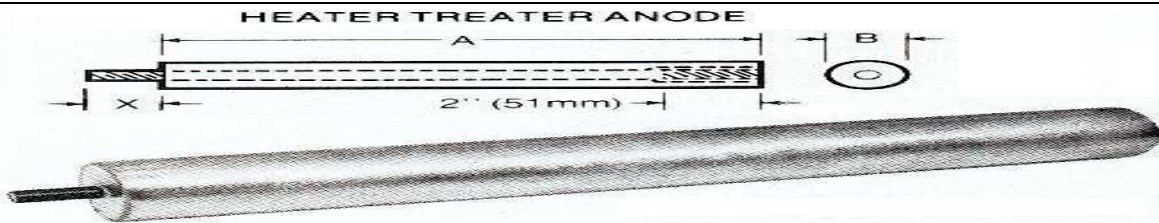

PART No.	Weight (Lbs)	A	B	X	MOUNTING
Treater Z321	39	21.5"	3.0"	1.0, 1.5"	Threaded
Treater Z321A	39	21.5"	3.0"	4.0"	Threaded
Treater Z330	56	30.0"	3.0"	1.0, 1.5"	Threaded
Treater Z330A	56	4.0"	1.25"	4.0"	Threaded

**Types 321 & 321A use 0.625" NF rod. Types 330 & 330A use 0.75" NC rod.
Other rod sizes and extended lengths may be specified by purchaser.**



ALCHEMY CASTINGS
563 KENILWORTH AVE N
HAMILTON, ONTARIO
CANADA - L8H 4T8

TOLL FREE: (866) 312-9084
Telephone: (905) 312-9084
Fax: (905) 312-9085

www.alchemycastings.com

COMMERCIAL ANODES

PROPELLER NUT ANODES

PART No.	Weight (Lbs)	A	B	C
CA	2	2.0"	2.75"	2.875"
CB	2.5	2.25"	3.0"	3.0"
1	4	2.5"	3.375"	3.625"
2	5.5	2.875"	3.75"	4.0"
3	6	3.25"	4.125"	4.0"
4	7.5	3.75"	4.625"	4.5"
5	11	4.25"	5.25"	5.0"
6	11.5	4.625"	5.625"	5.5"
7	13	5.0"	6.0"	6.0"
8	16.75	5.5"	6.625"	6.375"
9	19.5	6.0"	7.125"	6.75"
10	25	6.5"	7.75"	7.0"
11	28	7.0"	8.125"	8.125"
12	37	7.5"	8.75"	9.0"

PROPELLER NUT ANODE

Stud Hole and Stud are not provided.

BALLAST TANK ANODES

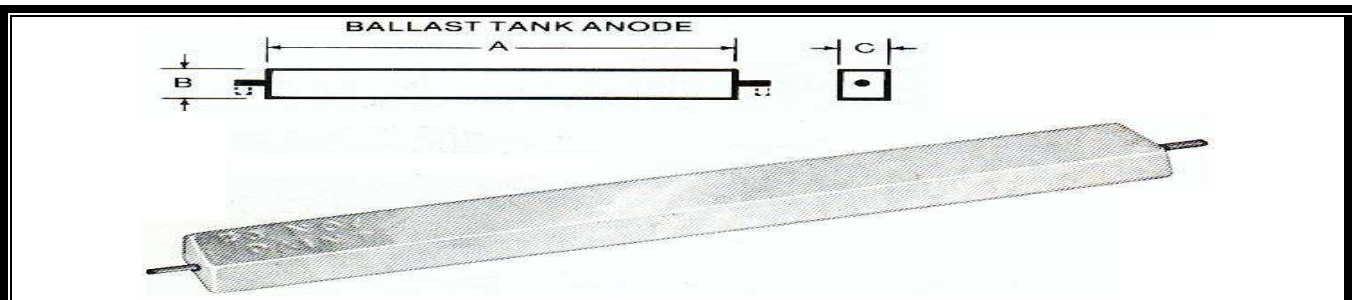

PART No.	Weight (Lbs)	A	B	C	MOUNTING
ZMA 2601	55 *	60.0" *	2.0"	2.0"	Weld-on
ZMA 3602	85 *	60.0" *	2.5"	3.0"	Weld-on
ZMA 31003	280 *	100.0" *	3.5"	3.25"	Weld-on
ZMA 41004	335 *	100.0" *	4.0"	3.75"	Weld-on

- Ballast tank anodes are available in any length up to the maximum shown above. Supplied with bent or straight tabs.
- Types MA 2602 & MA 3602 use 0.5" rod. Types MA 31003 & MA 41004 use 0.75" rod.



ALCHEMY CASTINGS
 563 KENILWORTH AVE N
 HAMILTON, ONTARIO
 CANADA - L8H 4T8

TOLL FREE: (866) 312-9084
 Telephone: (905) 312-9084
 Fax: (905) 312-9085

www.alchemycastings.com

COMMERCIAL ANODES

PLATE & ROD STOCK

Dimensions	Weight (Lbs)	Dimensions	Weight (Lbs)	Dimensions	Weight (Lbs)
PLATE STOCK					
1/2" x 3" X 3"	1.25	3/4" x 3" X 3"	1.75	1" x 3" X 3"	2.25
1/2" x 3" X 6"	2.5	3/4" x 3" X 6"	3.5	1" x 3" X 6"	4.5
1/2" x 4" X 6"	3.2	3/4" x 4" X 6"	4.6	-	-
1/2" x 6" X 6"	4.75	3/4" x 6" X 6"	7	1" x 6" X 6"	9.0
1/2" x 6" X 12"	1.25	3/4" x 6" X 12"	14	1" x 6" X 12"	18.0
ROD STOCK					
3/8" Dia x 6 FT	2	1/2" Dia x 6 FT	3.6	5/8" Dia x 6 FT	5.8
3/4" Dia x 6 FT	8.3	1" Dia x 6 FT	14.6	1-1/4" Dia x 6 FT	22
1-1/2" Dia x 6 FT	12	2" Dia x 2 FT	21	3" Dia x 6 FT	43
3-3/4" Dia x 2 FT	73				